

Submersible Waste Water Pump

Ama-Drainer 80/100

Type Series Booklet



Legal information/Copyright

Type Series Booklet Ama-Drainer 80/100

All rights reserved. The contents provided herein must neither be distributed, copied, reproduced, edited or processed for any other purpose, nor otherwise transmitted, published or made available to a third party without the manufacturer's express written consent.

Subject to technical modification without prior notice.

© KSB SE & Co. KGaA, Frankenthal 12/09/2018

Contents

Building Services: Drainage	4
Drainage Pumps / Waste Water Pumps	4
Ama-Drainer 80/100	4
Main applications.....	4
Fluids handled	4
Operating data.....	4
Design details	4
Designation	5
Materials.....	5
Product benefits.....	5
Certification.....	5
Overview of product features / selection tables	6
Technical data	7
Characteristic curves.....	8
Dimensions	9
Accessories.....	11
Exploded view and list of components.....	17

Building Services: Drainage

Drainage Pumps / Waste Water Pumps

Ama-Drainer 80/100



Main applications

- Drainage
- Disposal
- Drainage systems
- Lowering groundwater levels
- Maintaining groundwater levels
- Draining of pits, shafts, etc.
- Building site drainage
- Construction pit drainage
- Emergency pump in the event of flooding

Fluids handled

Standard design

- Slightly contaminated water
- Solid particles with a particle size of up to 12 mm

Variant B/BH

- Water containing sand

Operating data

Operating properties

Characteristic		Value
Flow rate	Q [m ³ /h]	≤ 130
	Q [l/s]	≤ 36
Head	H [m]	≤ 26
Fluid temperature	T [°C]	≤ +50 (continuous duty, standard design)
		≤ +40 (continuous duty, variant B/BH)
		≤ +90 (short-time operation, ≤ 3 minutes)
Immersion depth	ET [m]	≤ 7 (standard design)
		≤ 10 (variant B/BH)

Design details

Design

- Fully floodable submersible motor pump
- Close-coupled design
- Single-stage
- To EN 12050-2
- Vertical discharge nozzle
- With or without level control
- Wetted parts made of materials coated with anti-corrosive

Installation

- Vertical installation
- Wet-installed transportable model
- Wet-installed stationary model

Drive

- Motor winding to IEC 60038
- Motor design to EN 60043 T1/IEC 34-1
- Thermal class B
- DOL starting or star-delta starting
- Enclosure IP68 (permanently submerged) to EN 60529 / IEC 529

Standard design:

- 10-metre power cable

Variant B/BH:

- 20 m power cable

Ama-Drainer 80 N/S:

- Surface-cooled three-phase motor
- Integrated temperature switch
- Power cable and CEE plug with phase inverter
- Phase sequence indicator
- Over-current trip

Ama-Drainer 100 N/S¹⁾:

- Surface-cooled three-phase motor
- Integrated temperature switch
- Power cable with free cable ends

1) Switchgear / control unit available separately

Shaft seal

- Pump end: 1 mechanical seal
- Drive end: 1 mechanical seal
- Liquid reservoir between the seals for cooling and lubrication

Impeller type

- Open multi-vane impeller

Bearings

- Maintenance-free
- Grease-packed rolling element bearings sealed for life

Electrical connection

Ama-Drainer (B/BH) 80 for DOL starting:

- Ama-Drainer pump sets for 3~400 V are supplied ready to be plugged in as standard. The scope of supply includes a power cable, CEE plug, phase inverter, phase sequence indicator, equipment-on lamp, fault indicator lamp, manual-0-automatic selector switch, motor protection relay. For commissioning simply insert the plug into the socket.

Ama-Drainer (B/BH) 100 for star-delta starting:

- Ama-Drainer pump sets are supplied with a 4-wire and a 7-wire motor power cable. The cable ends are marked. A switchgear/control unit with star-delta combination, manual-0-automatic selector switch, motor protection switch and terminals is available as an accessory.

Materials

Overview of available materials

Component	Standard material variant	Material variant B/BH
Pump casing	Grey cast iron EN-GJL-250 (EN-GJL-250)	Grey cast iron EN-GJL-250 (EN-GJL-250) with rubber insert
Suction cover	Steel, CK 45 N	
Pump foot	Polystyrene	
Impeller	Grey cast iron EN-GJL-250 (EN-GJL-250)	B: Grey cast iron EN-GJL-250 (EN-GJL-250) BH: Norihard NH 15 3 (G-X250CrMo153)
Profile joint, O-ring	Nitrile butadiene rubber	
Mechanical seal	Tungsten carbide	
Stator case, motor housing	Aluminium, plastic-coated	
Rotor shaft	Chrome steel (1.4021)	
Motor power cable	Polychloroprene rubber (CR)	
Float switch (float)	Polypropylene (PP)	-
Oil supply	Thin-bodied paraffin	

Product benefits

- Ready-to-connect, easy installation and commissioning
- Reliable shaft sealing by SiC/SiC mechanical seal with good dry-running characteristics, with oil reservoir
- Maintenance-free with grease-packed bearings sealed for life
- Suitable for handling water containing sand (variant B/BH)

Designation

Example: Ama-Drainer B 80-40 S

Designation key

Code	Description
Ama-Drainer	Type series
B	Material
B	Wear-resistant variant
BH	Wear-resistant variant with impeller made of Norihard white cast iron
- ²⁾	Design for waste water
80	Discharge nozzle DN
80	80 mm
100	100 mm
40	Motor rating [kW x 10]
40	4.0 kW
75	7.5 kW
S	Float switch
S	With float switch
N	Without float switch

Certification

Overview

Label	Effective in:	Comment
	Europe	-

2) Blank = standard design = design for waste water

Overview of product features / selection tables
Table of fluids handled

The table of fluids handled is a selection aid for different applications. It serves as guidance and is based on long-standing experience. The data are reference values and are not to be considered generally binding recommendations. They shall not be the basis for warranty claims. Please contact your nearest sales branch for in-depth advice.

Table of fluids handled

X = standard

Fluid handled	Temperature	Percentage	Material variant	
	[°C]	[%]	Standard	B/BH
Ammonium hydroxide NH ₄ OH	≤30	10	X	-
Calcium hydroxide (milk of lime) Ca(OH) ₂	≤30	-	-	X
▪ Impeller made of grey cast iron	-	10	-	X
▪ Impeller made of Norihard	-	25	-	X
Calcium nitrate (acid-free) Ca (NO ₃) ₂	-	10	X	-
Potassium carbonate	-	-	X	-
Potassium hydroxide KOH	≤30	10	X	-
Potassium nitrate (acid-free) KNO ₃	-	10	X	-
Magnesium sulphate (acid-free) MgSO ₄	-	10	X	-
Sodium hydroxide NaOH	≤30	10	X	-
Sodium carbonate Na ₂ CO ₃	-	10	X	-
Sodium nitrate (acid-free)	-	-	X	-
Sodium perborate	-	-	X	-
Sodium sulphate (acid-free) Na ₂ SO ₄	-	10	X	-
Trisodium phosphate	-	-	X	-
Washing machine lye	-	-	X	-
Water				
▪ Drainage water	-	-	X	X
▪ Fire-fighting water	-	-	X	X
▪ Heating water	-	-	X	-
▪ Boiler water	-	-	X	-
▪ Cooling water	-	-	X	-
▪ Stormwater	-	-	X	X
▪ Raw water	-	-	X	X
▪ Partly desalinated water	-	-	X	-
Waste water containing solids	-	-	-	X
Waste water containing abrasive sand	-	-	-	X
▪ Impeller made of grey cast iron ≤ 2 g/l	-	-	-	X
▪ Impeller made of Norihard ≤ 10 g/l	-	-	-	X
Building site drainage	-	-	-	X
Construction pit drainage	-	-	-	X
Wash water in sugar mills	-	-	-	X
Waste water containing dust/ash	-	-	-	X
Lime water	-	-	-	X
▪ Impeller made of Norihard ≤ 5 g/l	-	-	-	X
Emergency pumping (floods)	-	-	-	X

Special programme (upon request)

For improved fire protection in building services. Variant: power supply cables free from halogen and noxious substances

Technical data

Material variants Standard/B/BH

Size	Free passage	P ₁	P _N	I _N 3-400 V	Power cable H07RN-F		Level control H07RN-F		Mat. No.	[kg]
	[mm]				[kW]	[kW]	[A]	[m]		
Standard variant										
80-40 N	12	5,10	4,00	Y 8,5	10	7×1,5	-	-	29117702	59
80-40 S	12	5,10	4,00	Y 8,5	10	7×1,5	0,5	3×1,0	29117703	59,5
100-75 N	12	9,10	7,50	Y Δ 15,4	2×10	7×1,5 and 4×1,5	-	-	29117706	93
100-75 S	12	9,10	7,50	Y Δ 15,4	2×10		10	3×1,0	29117707	94,5
B: wear-resistant variant										
B 80-40 N	12	5,10	4,00	Y 8,5	20	7×1,5	-	-	29117722	65
B 80-40 S	12	5,10	4,00	Y 8,5	20	7×1,5	0,5	3×1,0	29117723	65,5
B 100-75 N	12	9,10	7,50	Y Δ 15,4	2×20	7×1,5 and 4×1,5	-	-	29117726	106
B 100-75 S	12	9,10	7,50	Y Δ 15,4	2×20		20	3×1,0	29117727	109
BH: wear-resistant variant with impeller made of Norihard white cast iron										
BH 80-40 N	12	5,10	4,00	Y 8,5	20	7×1,5	-	-	29127336	65
BH 80-40 S	12	5,10	4,00	Y 8,5	20	7×1,5	0,5	3 × 1.0	29127337	65,5
BH 100-75 N	12	9,10	7,50	Y Δ 15,4	2×20	7×1,5 and 4×1,5	-	-	29127338	106
BH 100-75 S	12	9,10	7,50	Y Δ 15,4	2×20		20	3×1,0	29127339	109

Special connection elbow see pump accessories (⇒ Page 11)

Characteristic curves

Ama-Drainer 80/100; n = 2800 rpm, multi-vane impeller

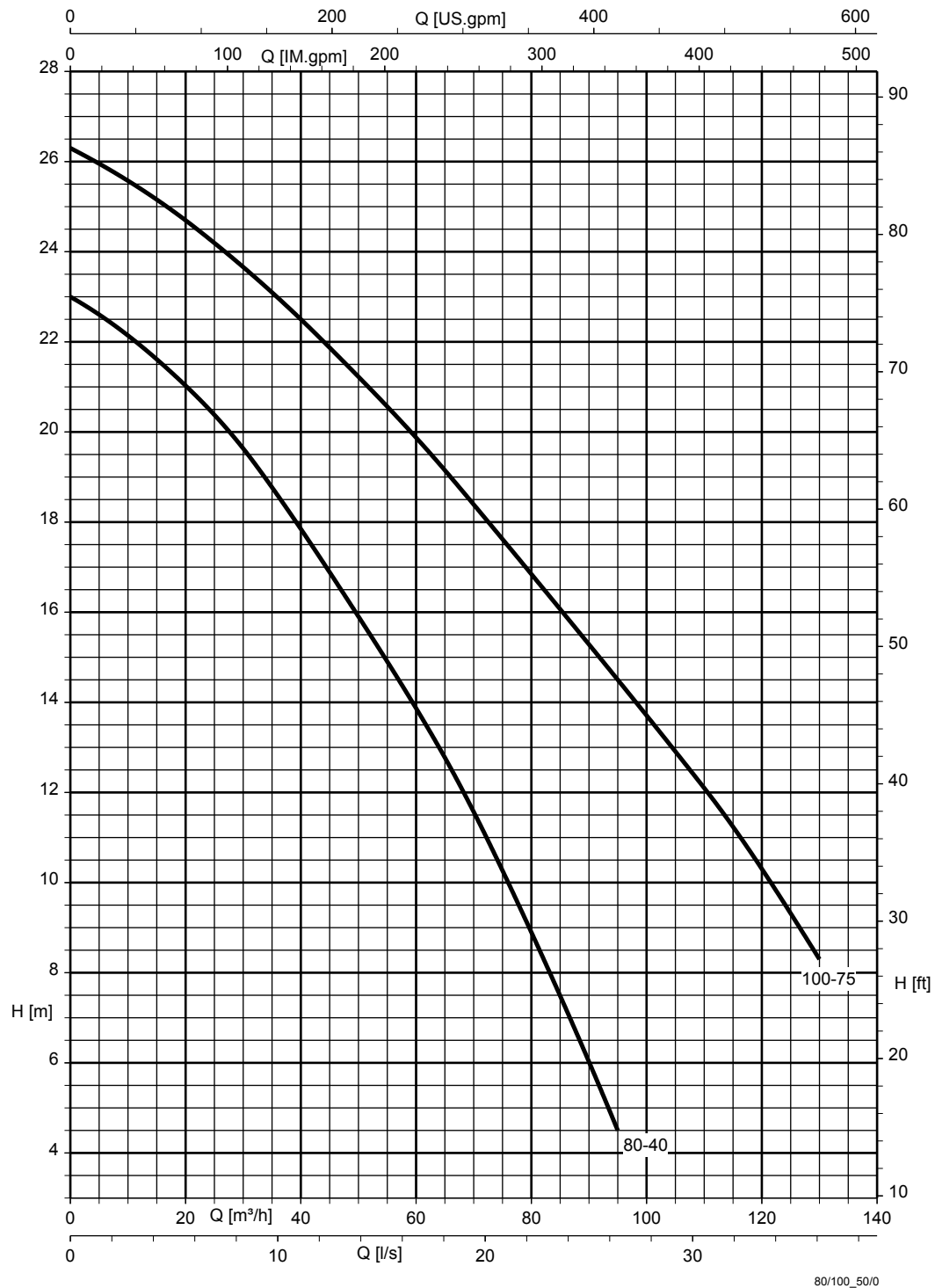
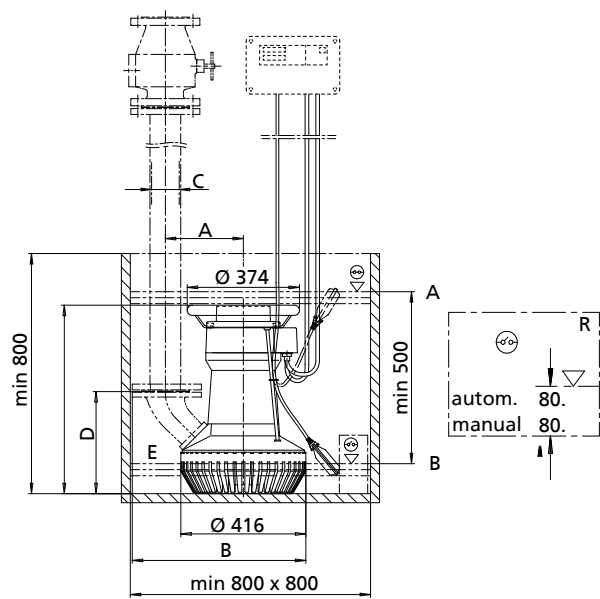
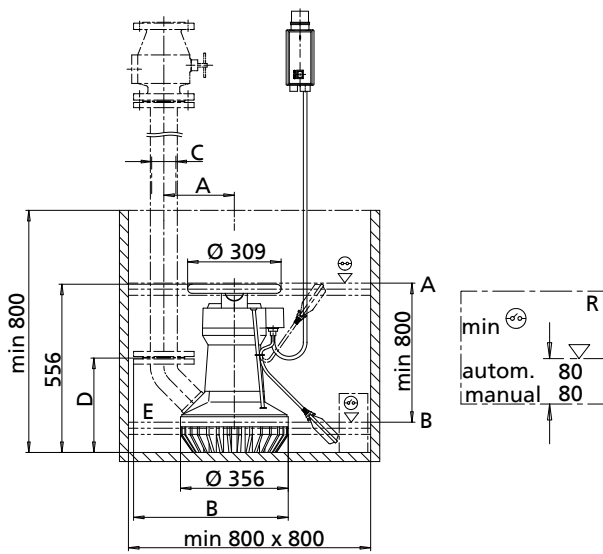

Fig. 1: Free passage: Ama-Drainer 80/100 = 12 mm
Performance tolerance to ISO 2548 Class C (water under standard conditions)

Dimensions

80 SD

100 SD



R	Residual water level	"A"	Start-up level
a)	Automatic	"B"	Stop level
b)	Manual	E	Vent hole

Dimensions [mm]

Description	Connection	A		B		C		D	
		80	100	80	100	80	100	80	100
Connection elbow with internal thread	Rp 2 1/2	223	-	445	-	Rp 2 1/2	-	314	-
	Rp 4	-	275	-	546	-	Rp 4	-	383
Flanged connection elbow	DN 80, PN 16	233	-	511	-	80	-	312	-
	DN 100, PN 16	-	260	-	578	-	100	-	340

Installation example of a dual-pump station

80/100 ND

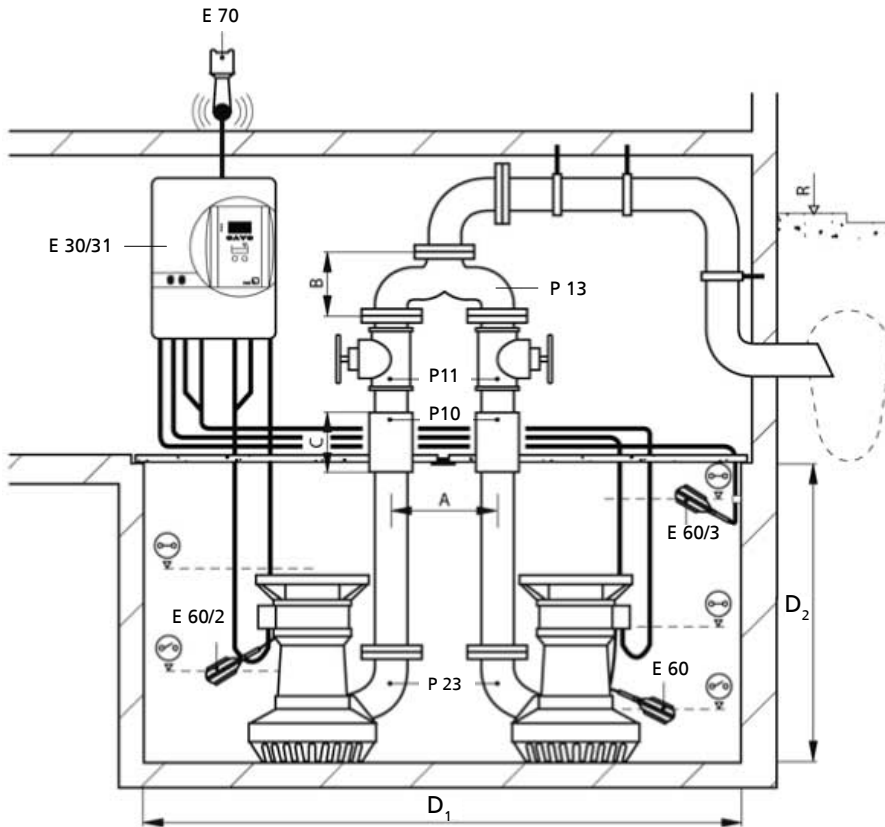

P 10	Check valve	E 60	Float switch, base load
P 11	Gate valve	E 60/2	Float switch, peak load
P 13	Y-pipe	E 60/3	Float switch, high water alert
P 23	Connection elbow	E 70	Horn
E 30/31	Control unit	R	Flood level





Dimensions [mm]

Ama-Drainer	A			B			C	D ₁	D ₂
	DN65	DN80	DN100	DN65	DN80	DN100			
80	325	350	-	230	260	-	260	1690 (x 800)	1000
100	-	-	325	-	-	295	300	1690 (x 800)	1000

Accessories
Pump accessories

	Item	Description	Connection / immersion depth	Ama-Drainer		Mat. No.	[kg]
				80	100		
	P10	KSB swing check valve, grey cast iron With full port, lifting device, flanges drilled to DIN 2501, PN 16	DN 65	X	-	48829253	16,2
			DN 80	X	-	48829254	21,5
			DN 100	-	X	48829255	29
		Swing check valve to KSB's choice Grey cast iron, with full port, lifting device, flanges drilled to DIN 2501, PN 16 (not for lifting units)	DN 65	X	-	01056711	16
			DN 80	X	-	01056712	21
			DN 100	-	X	01056713	30,9
	P11	Gate valve to KSB's choice. PN 10, grey cast iron, flanges drilled to PN 10 / PN 16, to EN 1092-1/2	DN 65	X	-	01056707	17
			DN 80	X	-	01056708	18,9
			DN 100	-	X	01056709	22,5
	P12	Set of installation accessories for flange connection, comprising: 4 or 8 hexagon head bolts with nuts and 1 sealing element	DN 65	X	-	18072643	0,67
			DN 80	X	X	18072644	1
			DN 100	-	X	18060163	1,4
	P13	Y-pipe for dual-pump sets, grey cast iron, with hexagon head bolts, nuts and gaskets; flanges drilled to DIN 2501	DN 65	X	-	40000690	18,3
			DN 80	X	-	48936065	25
			DN 100	-	X	40000692	31
	P23	Special connection elbow, grey cast iron, PN 16 (must be ordered separately)	I Rp 2 1/2	X	-	11150456	2,7
			DN 65	X	-	11150457	5,8
			DN 80	X	-	11150458	5,8
			I Rp 4	-	X	11150459	5
			DN 100	-	X	11150869	8
	P24	Storz rigid coupling with external thread to DIN ISO 228/1 Aluminium alloy	B 75 - G 2 1/2	X	-	00524371	0,4
			A - G 4	-	X	00522546	1
	P25	Storz rigid coupling with flange, to DIN 2501, drilled to PN 16 (to be used for flange connection item 25 or item 26), aluminium/steel	DN 65/B 75	X	-	18040148	3,5
			DN 80/B 75	X	-	18072642	3,5
			DN 100/A 110	-	X	18060162	5
	P26	Storz hose coupling, aluminium alloy	B 75 (DIN 14322)	X	-	00520454	0,7
			A 110 (DIN 14323)	-	X	00522313	1,5
	P27	Hose clip DIN 3017, chrome steel	AL 70-90 B (DIN 3017)	X	-	01063363	0,032
			AL 110 - 120 B	-	X	00520853	0,1
	P28	Plastic hose DN 75, with integrated B couplings, DIN 14811 Plastic hose DN 75, without couplings (max. 30 m), DIN 14811 Plastic hose DN 100, without couplings (max. 30 m), DIN 14811	B 75-20 m	X	-	00522265	10
			B 75 per m	X	-	00540104	0,3
			per m	-	X	00523966	0,5

Control units / switchgear

	Item	Description	400 V	Type	Ama-Drainer		Mat. No.	[kg]
					80	100		
	E2	Motor protection switchgear MSD Float switch Dimensions (H x W x D): 100 x 170 x 112 mm	X	100.1	X	-	19070119	1
	E10	LevelControl Basic 2 control unit for single-pump station Required in addition: 1 float switch or 4...20 mA sensor, optionally with master switch DOL starting, with manual-0-automatic selector switch, indicator lamps and control panel, high water alert, integrated alarm buzzer 85 dB(A), optional mains-independent alarm via rechargeable battery, operating hours counter / start-stop cycles per pump, voltage measurement, phase monitoring, pneumatic level measurement, indication of water level, volt-free contact for general fault message. Motor temperature warning (thermal circuit breaker) – self-acknowledging, motor leakage/moisture monitoring Dimensions (H x W x D): BC: 400 x 281 x 135 mm BS: 600 x 400 x 200 mm	X	BC1 400 ^{DFNO} 100	X	-	19073765	4,5
	E12		X	BS1 400 ^{SFNO} 180	-	X	19073795	20
	E31	LevelControl Basic 2 control unit for dual-pump station Required in addition: 1 float switch or 4...20 mA sensor, optionally with master switch DOL starting, with manual-0-automatic selector switch, indicator lamps and control panel, high water alert, integrated alarm buzzer 85 dB(A), optional mains-independent alarm via rechargeable battery, operating hours counter/start-stop cycles per pump, voltage measurement, phase monitoring, pneumatic level measurement, indication of water level, volt-free contact for general fault message. Motor temperature warning (thermal circuit breaker) – with automatic reset/re-start function Motor leakage/ moisture monitoring Dimensions (H x W x D): BC: 400 x 281 x 135 mm BS: 800 x 600 x 200 mm	X	BC2 400 ^{DFNO} 100	X	-	19073779	4,7
	E32		X	BS2 400 ^{SFNO} 180	-	X	19073837	30
Optional components for LevelControl Basic 2³⁾								
-	O1	Master switch for type BC, fitted 3-pole, 20 A, lockable	-	-	X	-	01143084	0,2
-	O2	Control cabinet heating for type BS, fitted with 20 W thermostat	-	-	-	X	19074269	0,3

LevelControl with float switch(es)

Single-pump station:

At least 1 float switch for pump On/Off

At least 2 float switches for pump On/Off and high water alert

Dual-pump station:

At least 2 float switch for pump On/Off

At least 3 float switches for pump On/Off and high water alert

Twin operation with two level switches at different levels

If two pumps are used in the same location, we recommend operating them via the LevelControl unit. This enables automatic alternating, peak load and stand-by operation. External alarm switchgear will not be required as LevelControl features an integrated alarm function.

3) Unless processed via KSB EasySelect, optional components will be supplied with the unit but not fitted.

Connection to the control station

With the exception of MSD, each control unit / switchgear features a volt-free contact for transmitting the general fault message to the control station.
 Optional components are not EDI-compatible (configurable range).

LevelControl Basic 2 control units

Symbols key

Symbol	Description
o	Optional
x	Control unit feature
-	Not a control unit feature





Comparison of functions of single-pump stations and dual-pump stations

Feature	Single-pump station Float switches incl. 4-20 mA		Dual-pump station Float switches incl. 4-20 mA	
	BC1 400 _{DFNO} 100	-	BC2 400 _{DFNO} 100	-
400 V: 6-10 A	BC1 400 _{DFNO} 100	-	BC2 400 _{DFNO} 100	-
400 V: 13-18 A	-	BS1 400 _{SFNO} 180	-	BS2 400 _{SFNO} 180
Functions				
Draining	x	x	x	x
Filling via float switch(es)	x	x	x	x
Stand-by pump: 1 pump redundant	-	-	x	x
Pump changeover after each start	-	-	x	x
Pump changeover in the case of a pump fault	-	-	x	x
Peak load operation function	-	-	x	x
Runtime limitation	x	x	x	x
OFF via after-run time	x	x	x	x
OFF via level	x	x	x	x
Functional check run after idle period	x	x	x	x
Display and operation				
7-segment display	x	x	x	x
Indication of water level	Switching points	Switching points	Switching points	Switching points
Operation/fault/pump running (displayed for each pump)	Multicolour LED	Multicolour LED	Multicolour LED	Multicolour LED
General fault (traffic light)	LED	LED	LED	LED
High water	LED	LED	LED	LED
Mains voltage	x	x	x	x
Operating hours of each pump	x	x	x	x
Operating hours of the system	-	-	-	-
Starts per pump	x	x	x	x
Rotary field recognition of mains power supply	x	x	x	x
Phase monitoring	x	x	x	x
Change of switching level	-	-	-	-
Housing H x W x D [mm], IP54				
Plastic 400 x 281 x 135	x	-	x	-
Sheet steel 400 x 300 x 155	-	x	-	-
Sheet steel 800 x 600 x 200	-	-	-	x
Built-in components				
Master switch (lockable)	o	x	o	x
Manual-0-automatic selector switch per pump	x	x	x	x
DOL starting	x	-	x	-
Star-delta starting	-	x	-	x
Motor protection				
Motor protection switch	x	x	x	x
Motor temperature warning input	x	x	x	x
Motor temperature alert input	x	x	x	x
Pump				
Thermal circuit breaker/bimetal	x	x	x	x
Optional components				
Rechargeable battery for powering the device	o	o	o	o
Control cabinet heating, type BS	-	o	-	o

Feature	Single-pump station Float switches incl. 4-20 mA		Dual-pump station Float switches incl. 4-20 mA	
Alarm equipment				
1 free alarm input	X	X	X	X
1 digital input for high water alert	X	X	X	X
Volt-free contact (changeover contact) for general fault message / "in operation" message	X	X	X	X
Piezo buzzer 85 dB(A)	X	X	X	X
Horn / alarm combination / alarm strobe light 12 V DC	o	o	o	o
Inputs/outputs				
Inputs for float switches	4	4	4	4
4-20 mA analog input	X	X	X	X
Pneumatic pressure sensor	-	-	-	-
Bubbler control with compressor up to 2 metres of water	-	-	-	-
Remote acknowledgement	X	X	X	X
12 V DC connection for horn, etc.	X	X	X	X
Sensors				
Float switch (NO contact)	o	o	o	o
F1 leakage sensor	o	o	o	o
Tools				
KSB ServiceTool for Windows XP	o	o	o	o





Alarm switchgears for pumps without ATEX

AS 0/AS 1/AS 2/AS 4/AS 5

	Item	Description	Mat. No.	[kg]
	E50	Alarm switchgear AS 0 with circuit breaker, acoustic signal transmitter with 85 dB(A), green equipment-on lamp Plastic housing, IP20, H x W x D = 140 x 80 x 57 [mm]. Use float switch, F1 leakage sensor (item E64), M1 alarm contactor or signal relay of control unit as contactor.	29128401	0,5
	E51	Alarm switchgear AS 2 With circuit breaker, acoustic signal transmitter with 85 dB(A), green equipment-on lamp, volt-free contact for hook-up to a control station Plastic housing, IP20, H x W x D = 140 x 80 x 57 [mm]. Use float switch, F1 leakage sensor (item E64) or signal relay of control unit as contactor.	29128422	0,5
	E52	Alarm switchgear AS 4 With circuit breaker, acoustic signal transmitter with 85 dB(A), green equipment-on lamp, volt-free contact for hook-up to a control station, self-charging power supply unit for 5 hours of operation in the event of a power failure Plastic housing, IP20, H x W x D = 140 x 80 x 57 [mm]. Use float switch (E60), F1 leakage sensor (item E64) or signal relay of control unit as contactor.	29128442	0,5
	E53	Alarm switchgear AS 5 Mains-independent, with self-charging power supply unit for 10 hours of operation in the event of a power failure, mains pilot LED, fault indicator light, horn-off pushbutton, volt-free contact for hook-up to a control station, ready for connection with 1.8 m connection cable and plug. ISO housing, IP41, H x W x D = 190 x 165 x 75 [mm]. Use float switch (E60) or signal relay of control unit as contactor.	00530561	1,7
	E55	Alarm switchgear AS 1 In IP30 ISO plug housing, mains-independent, with self-charging power supply unit for 5 hours of operation in the event of a power failure, acoustic signal transmitter 70 dB(A) with circuit breaker and integrated signal transmitter with 3-metre connection cable, max. 60 °C, not suitable for steam and condensate. 1. High water alert by suspending the sensor in a (pump) sump above the pump start-up point. 2. Water alarm signal at a water level of only 1 mm (!), by placing the sensor on the floor in areas with a leakage risk, e.g. the cellar or next to the washing machine in the kitchen or bathroom.	00533740	0,9

Control unit / switchgear accessories

Overview of control units

	Item	Description	Power cable length	Ama-Drainer		Mat. No.	[kg]
				80	100		
	E60	Float switch with free cable end Switch housing made of polypropylene (fluid temperature 70 °C max.) 230 V AC or 24 V AC/DC, 8 A max., 20 mA min. Function: circuit closed in upper float position (NO contact) Power cable: H07RN-F 3G1	3	X	X	11037742	0,5
			5	X	X	11037743	0,8
			10	X	X	11037744	1,3
			15	X	X	11037745	1,8
			20	X	X	11037746	2,4
			25	X	X	11037747	2,9
			30	X	X	11037748	3,4
	E61	Float switch with free cable end, oil-resistant Function: circuit closed in upper float position (NO contact) Power cable: PUR 3x1.0 mm ²	5	X	X	11037753	0,8
			10	X	X	11037754	1,2
			20	X	X	11037755	2
	E62	Float switch with free cable end ⁴⁾ Function: circuit open in upper float position (NC contact) Power cable: H07RN-F 3G1	5	X	X	11037756	0,8
			10	X	X	11037757	1,4
			20	X	X	11037758	2,6
	E64	F1 leakage sensor Contactor for alarm switchgears AS 0, AS 2, AS 4 or as alarm transmitter for LevelControl Possible applications for alarm transmission: <ul style="list-style-type: none"> ▪ High water alert by suspending the sensor in a (pump) sump above the pump start-up point. ▪ Warning at a water level of 1 mm in areas with a leakage risk (e.g. in the cellar or next to the washing machine in the kitchen or bathroom) Max. 40 °C, not suitable for steam and condensate. Dimensions [mm]: 52 x 21 x 20 (H x W x D)	3 m	X	X	19072366	0,2
	E70	Horn, 12 V DC, 105 dB, 150 mA, IP54 Suitable for indoor installation and outdoor installation. Keep dry.	0.45 m	X	X	01086547	0,1
	E80	Safety switch STECKMAT Trips in approx. 0.03 seconds, from approx. 0.03 A 230 V / 10 A		X	X	00534217	0,5
	E90	Rechargeable battery retrofit kit for LevelControl Basic 2, type BC For powering the electronics, float switches, level sensors, internal pressure sensor and the alarm equipment (buzzer, horn, alarm combination). For single-pump stations and dual-pump stations Scope of supply: 2 rechargeable batteries (6 V, 1.3 Ah) and charging unit		X	-	19074194	0,8
	E91	Rechargeable battery retrofit kit for LevelControl Basic 2, type BS For powering the electronics, float switches, level sensors, internal pressure sensor and alarm equipment (buzzer, horn). For single-pump stations and dual-pump stations Scope of supply: 1 rechargeable battery (12 V, 1.2 Ah) and charging unit		-	X	19074199	1

4) Not suitable for LevelControl Basic 2.

Exploded view and list of components

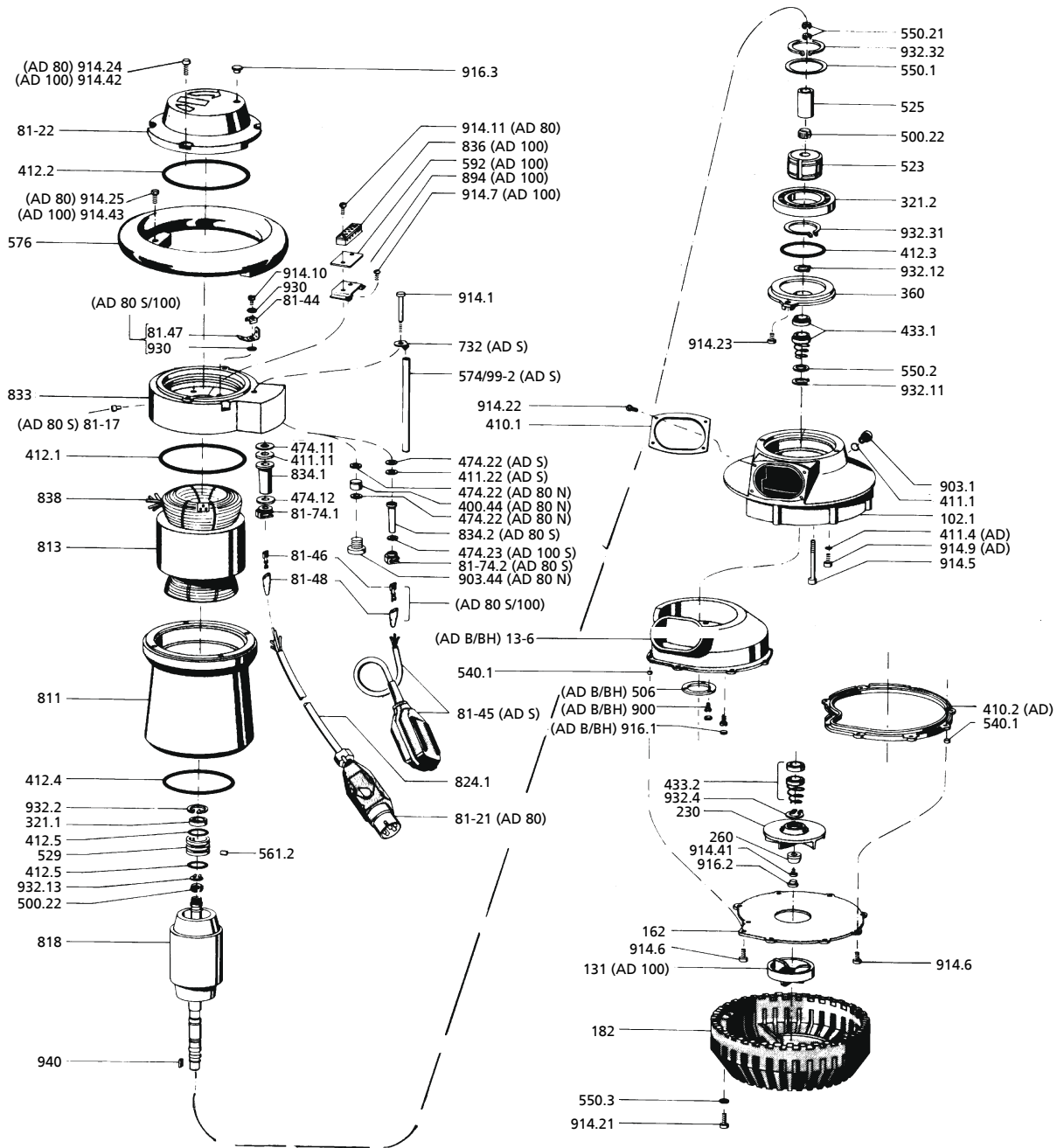

Fig. 2: Exploded view

List of components

Part No.	Description	Part No.	Description
102.1	Volute casing	81-17	End connector
13-6	Casing insert	81-21	CEE motor protection plug
131	Inlet ring	81-22	Terminal box cover
162	Suction cover	81-44	Terminal clamp
182	Pump foot	81-45	Float switch
230	Impeller	81-46	Plug-in sleeve
260	Impeller hub cap	81-47	Flat connector
321.1/2	Deep groove ball bearing	81-48	Coupling connector
360	Bearing cover	81-74.1/2	Pressure screw
400.44	Gasket	811	Motor housing
410.1/2 ⁵⁾	Profile seal	813	Stator core pack

5) Not applicable for Ama-Drainer B/BH

Part No.	Description	Part No.	Description
411.1/4 ⁵	Joint ring	818	Pump rotor
411.11/22	Joint ring	824.1	Cable
412.1-5	O-ring	833	Terminal box
433.1/2	Mechanical seal	834.1/2	Cable gland
474.11/12	Thrust ring	836	Terminal strip
474.22/23	Thrust ring	838	Temperature switch
500.21/22	Tolerance ring	894	Bracket
506	Retaining ring	900	Countersunk head screw
523	Shaft sleeve	903.1/44	Screw plug
525	Spacer sleeve	914.1/5/6/7	Hexagon socket head cap screw
529	Bearing sleeve	914.9 ⁵ /10/11	Hexagon socket head cap screw
540.1	Bush	914.21-.25	Hexagon socket head cap screw
550.1	Support disc	914.41/42	Hexagon socket head cap screw
550.2	Adjusting washer	914.43/5	Hexagon socket head cap screw
550.3	Disc	916.1/2/3	Plug
561.2	Grooved pin	930	Lock washer
574	Rod	932.11-.13/2	Circlip
576	Handle	932.31/32/4	Circlip
592	Shim	940	Key
732	Holder	99-2	Holder



KSB SE & Co. KGaA
Johann-Klein-Straße 9 • 67227 Frankenthal (Germany)
Tel. +49 6233 86-0
www.ksb.com